



KIT PART NUMBER 4844041
INSTRUCTIONS FOR FOR INSTALLING:
TRAY MOTORS COVERS AND SEALS
ON 484, 485, 486, 784, 785 & 786 FROZEN FOOD MODULES

CHECK THE PARTS RECEIVED IN THE KIT WITH THE PARTS LIST IN THESE INSTRUCTIONS. IF ANY PARTS ARE MISSING, CONTACT THE NATIONAL VENDORS PARTS DEPARTMENT IMMEDIATELY.

Read these instructions carefully before installing the kit.
Keep these instructions for part numbers and for future reference.

This kit contains the following :

PART NUMBER	DESCRIPTION	QUANTITY
4840072	INSTRUCTIONS - INSTALLATION - KIT - 4844041	1
4844032	SEAL - MOTOR SHIELD	3
4844035	COVER - TRAY MOTORS	3



1. Remove paper from the motor shield seal (4844032). Apply the adhesive side of seal to the tray motors cover (4844035).
2. Disconnect the wiring harness from the back of one of the trays in the frozen food module.
3. Remove the tray from frozen food module.
4. Loosen the two (2) screws (and lockwashers if applicable) on the back of the tray at the corners.
5. Install the tray motors cover/motor shield seal assembly onto the back of the tray as follows: Slide the lower lip of the tray motors cover under the screw heads (and lockwashers if applicable), and the top lip of the tray motors cover under the tray lip, above the motors.
6. Tighten the two (2) screws that were unscrewed in step 3 (ensuring that the tray motors cover is pushed toward the front of the tray) to secure the tray motors cover.

NOTE

Ensure that the lockwashers are on top of the tray motors cover lower lip.

7. Repeat steps 1 through 6 for the remaining frozen food module trays.
8. Reconnect the wiring harnesses to the backs of the trays in the frozen food module and reinstall the frozen food module trays

NOTE

Ensure that the wiring harnesses are reconnected to the proper trays.

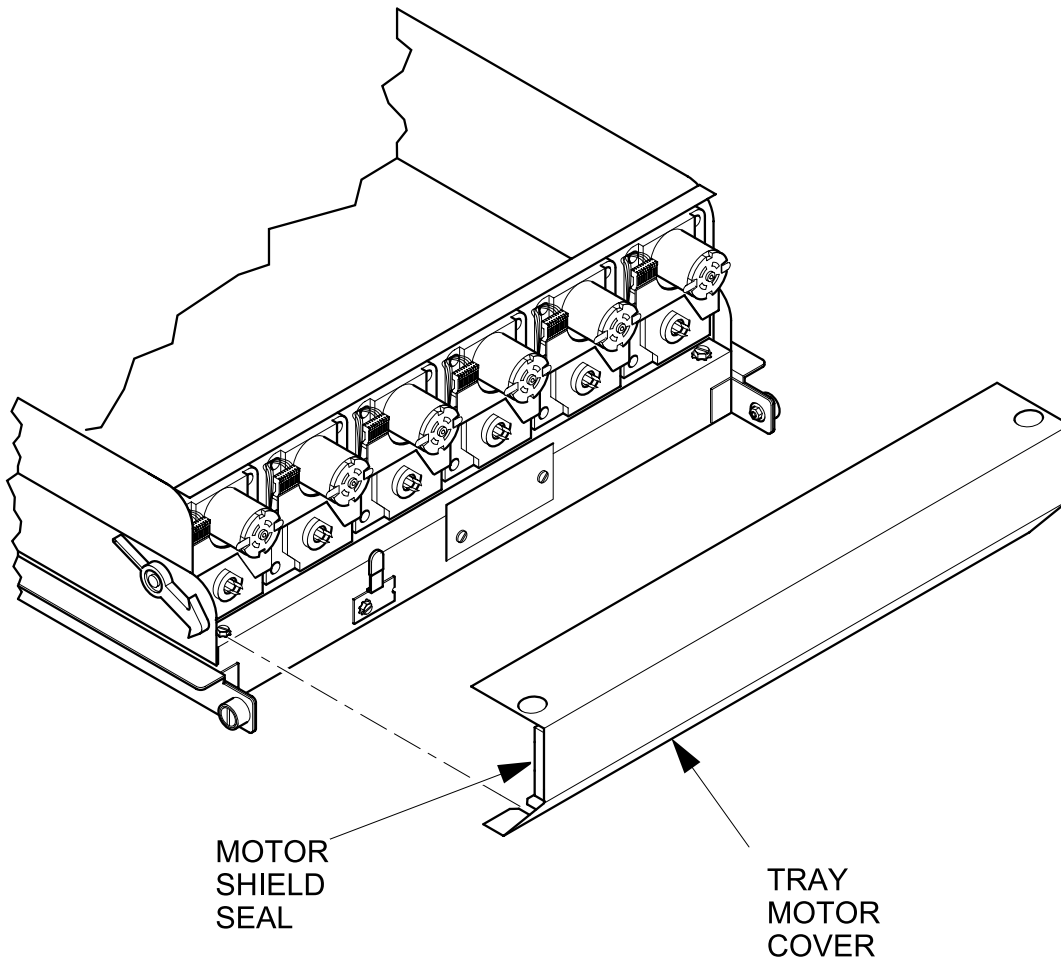

485pk0001

Figure 1